

Standard Lock Ring

Code SL

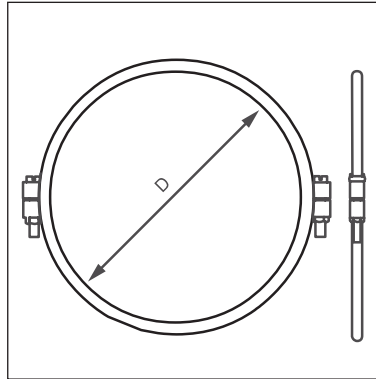

Dimensional specifications are given in the table below

Dimensional Specifications

PRODUCT CODE	D mm	Weight / 10 pcs kg
SL80	80	0.55
SL100	100	0.60
SL125	125	0.70
SL140	140	0.75
SL150	150	0.80
SL160	160	0.83
SL180	180	0.85
SL200	200	0.90
SL225	225	0.95
SL250	250	1.00
SL275	275	1.05
SL300	300	1.25
SL315	315	1.30
SL325	325	1.30
SL350	350	1.35
SL375	325	1.37
SL400	400	1.45
SL475	475	1.50
SL450	450	1.65
SL500	500	1.90

Material

Galvanised steel with nut and bolt closure

Sizes

80mm to 550mm diameter

Note

Should be used in association with Duct End Seals to ensure perfect system closure

