

Material

Two piece galvanised steel, with EDPM rubber insert and nut and bolt closure

Sizes

100mm to 450mm diameter

Heavy Lock Rings

Code *SLH*

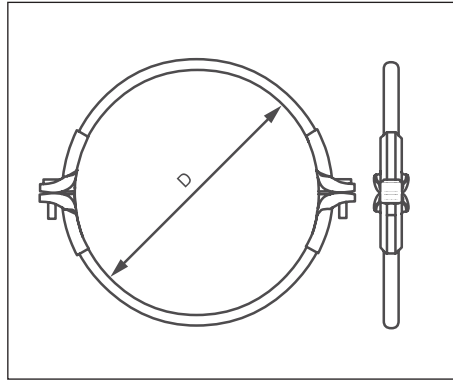

Dimensional specifications are given in the table below

Dimensional Specifications

PRODUCT CODE	D mm	Weight / 10 pcs kg
SLH100	100	1.87
SLH125	125	2.21
SLH150	150	2.38
SLH180	180	2.72
SLH200	200	2.83
SLH225	225	2.83
SLH250	250	2.83
SLH275	275	3.40
SLH300	300	3.57
SLH315	315	4.25
SLH350	350	4.42
SLH400	400	4.93
SLH450	450	5.61

