

Material

Galvanised steel, hinged, with PVC seal and quick release lever lock

Sizes

80mm to 550mm diameter

Options

Available with

Rubber seal for use up to 60°C

Silicone seal for use up to 200°C

Lever Lock Ring

Code LL

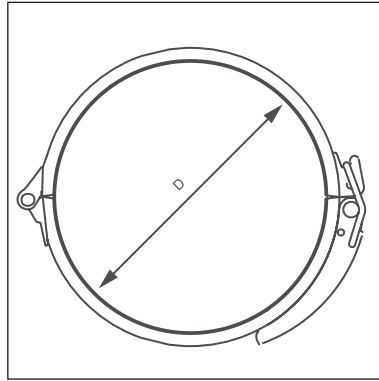

Dimensional specifications are given in the table below

Dimensional Specifications

PRODUCT CODE	D mm	Weight / 10 pcs kg
LL80	80	2.00
LL100	100	2.30
LL125	125	2.45
LL140	140	2.50
LL150	150	2.50
LL160	160	2.60
LL180	180	2.60
LL200	200	3.30
LL225	225	3.40
LL250	250	3.80
LL275	275	4.20
LL300	300	4.25
LL315	315	4.40
LL350	350	4.90
LL400	400	5.25
LL450	450	6.00
LL500	500	6.50
LL550	550	7.00

