

Material

3.0mm galvanised steel, 10mm hole

Sizes

325mm to 800mm diameter

Note

It is strongly recommended that Hanging Brackets and Bracket Legs be used every second length of duct.

Hanging Brackets and Bracket Legs

Code HB (Hanging Brackets)

Code WBL (Bracket Legs)

325mm to 800mm

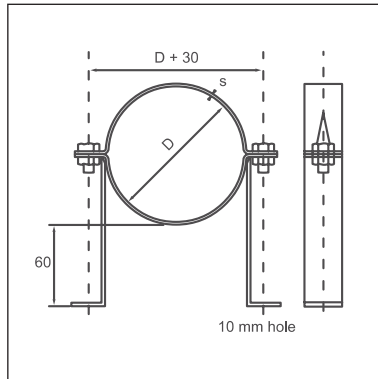

With legs

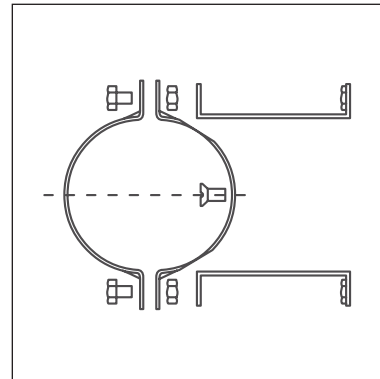

For wall mounting

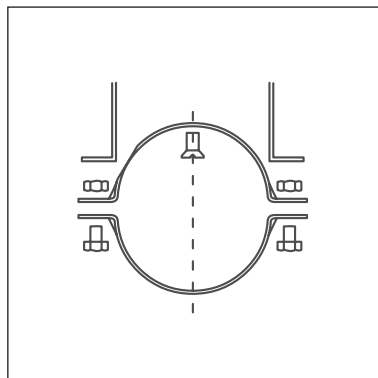

Suspended



Bracket Legs

Dimensional Specifications

D mm	S mm	Weight kg
325	3,00	1,80
350	3,00	1,95
375	3,00	2,20
400	3,00	2,50
425	3,00	2,65
450	3,00	2,80
500	3,00	3,00
550	3,00	3,35
600	3,00	3,60
630	3,00	3,70
650	3,00	3,85
700	3,00	4,00
750	3,00	4,35
800	3,00	4,80