

30° Conical Branch Pieces

Code BPC30

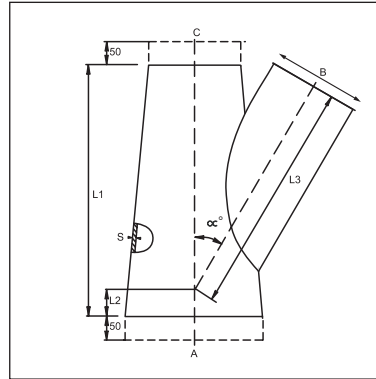

Dimensional specifications are given in the table below

Dimensional Specifications

A mm	B mm	C mm	L1 mm	L2 mm	L3 mm	α°	S mm
Choose (100 - 1000)	80	Choose (100 - 1000)	350	Calculated	Calculated	28.0	0.90
	100		350			28.8	0.90
	120		350			28.8	0.90
	125		400			29.0	0.90
	140		450			29.1	0.90
	150		450			29.2	0.90
	160		450			29.2	0.90
	180		550			29.3	0.90
	200		550			29.3	0.90
	225		600			29.4	0.90
	250		750	29.5	0.90		
	275		750	29.6	0.90		
	300		750	29.6	0.90		
	315		850	29.6	0.90		
	350		950	29.6	0.90		
	400		1050	29.7	0.90		
	450		1250	29.7	0.90		
	500		1250	29.7	0.90		
	550		1250	29.8	0.90		
	600		1450	29.8	0.90		
630	1650	29.8	0.90				
650	1650	29.8	0.90				
700	1650	29.8	0.90				
750	1850	29.9	0.90				
800	1850	29.9	0.90				
850	2050	29.9	0.90				
900	2050	29.9	0.90				

Material

0.9mm galvanised steel

Sizes

Common sizes are a stock item

Special requirements are

Manufactured to order

Dimensions

Refer to table – customer to specify A, B, & C

Please note the Branch 'B' determines L1, as in the table below

The maximum diameter reduction between A & C is 200mm. B must however, not be larger then or equal to $(A + C)/2$

In the case of double branch pieces, the largest branch determines Length L1

